



Converter Accessory Corporation
www.converteraccessory.com



Pneumatic Conveying Systems
www.foxtrimaway.com



Typical Two Pick-Up System

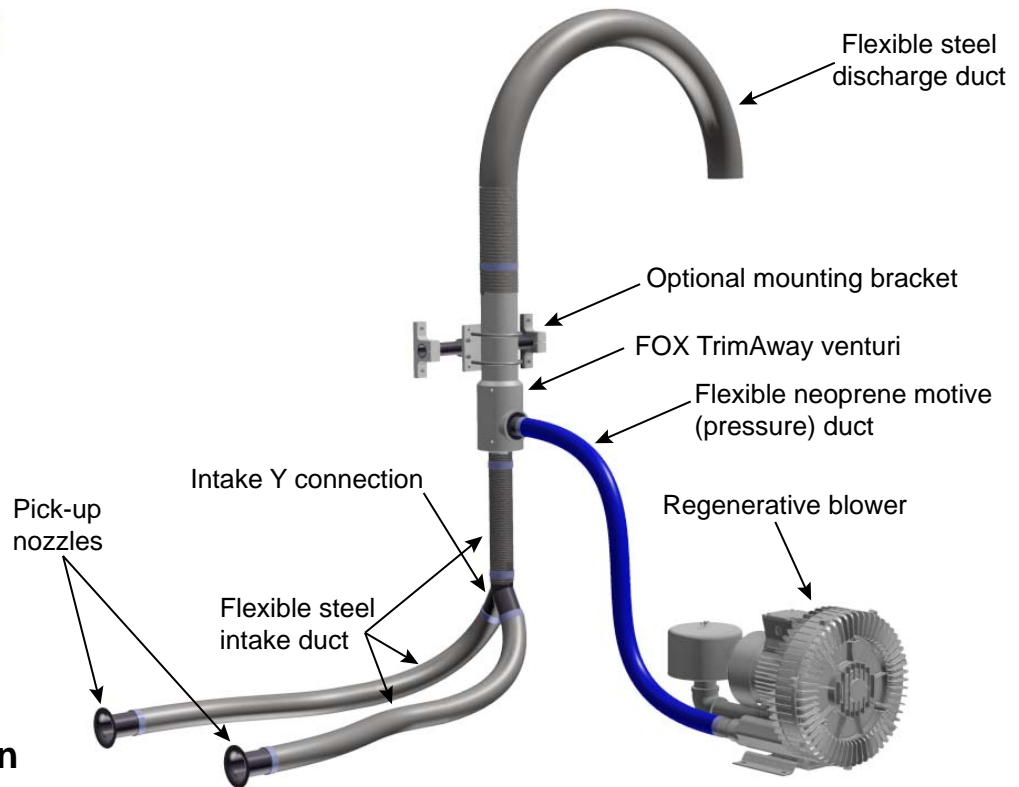

For more information
on this system, visit:

www.converteraccessory.com/systems

Unique Approach to Trim Removal

FOX TrimAway® systems are unique, utilizing regenerative blowers to generate a motivating air stream. The heart of the system, FOX TrimAway's exclusive venturi, converts the motivating air from the regenerative blower to high velocity suction at the intake and pressure at the discharge. The FOX system yields outstanding performance with genuine energy savings over other types of trim removal systems. They provide real return on investment when used in place of less efficient trim removal systems and systems that utilize compressed air.

FOX TrimAway systems are sized and matched to your specific requirements. Systems have an extensive 1/2 horsepower through 20 horsepower blower selection and three sizes of venturi's from which to choose. Rest assured, your system will be sized properly to provide you with the ultimate in performance, initial cost savings and long term operational cost savings.

- **Venturi** is aluminum construction - adjustable for individual material requirements
- PTFE lining is available where release is needed for pressure sensitive adhesive
- **Regenerative blowers** provide **high energy efficiency** and low maintenance
- Ducting is semi-rigid and rigid. Both available with PTFE lining
- **Complete systems** include all necessary components for **easy, fast** installation
- Systems are **quiet** without silencers. Noise levels well below other systems
- Compact venturi and blower takes up little space and are easy to mount with many mounting options and configurations
- Inline Chopper available



Pneumatic Conveying Systems
www.foxtrimaway.com

The Venturi Principle

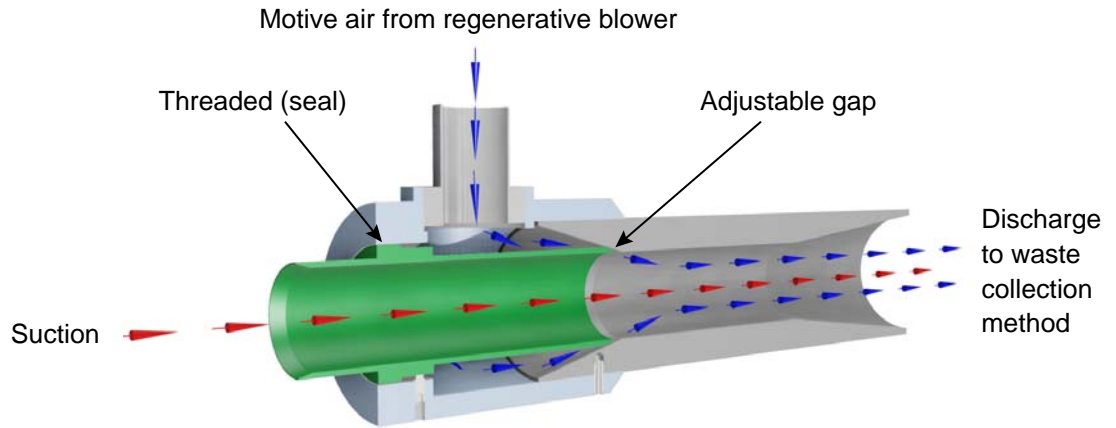

Unique Approach to Trim Removal

FOX TrimAway® systems utilize powerful and efficient regenerative blowers to generate “motive” air from the pressure output of the blower. This air flow is ported into the side of the venturi. The FOX TrimAway venturi is designed so that all of this motive (pressure) air must, in essence, make a perpendicular turn and flow through the adjustable gap in the venturi. The air is flowing at such a high rate and speed, suction is generated, due to Bernoulli’s principal, at the intake side of the venturi. Each FOX TrimAway system is factory tested and adjusted for maximum suction. However, the adjustable gap allows for suction adjustment in the field.

The waste (typically edge trim) is fed into the suction side of the venturi and takes a straight path through the venturi. This eliminates the trim from passing through any moving parts. Continuous trim can stay continuous, there is no need for it to be chopped, since it does not pass through any fan blades or other moving parts. System maintenance is very low since there are no moving parts coming in contact with the trim. After the waste enters the venturi and reaches the point where the motive air and suction air join, the waste can be conveyed long (or short) distances with a very powerful stream (combined suction and motive) of air to a waste collection point.

Typical Applications include:

- Paper, paperboard, film, foil, textiles and nonwovens
- Waste with adhesives
- Continuous trim
- Pieces
- Narrow to wide

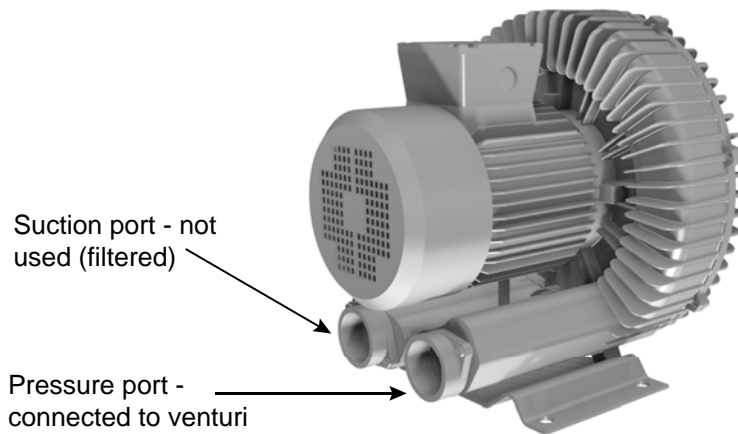

FOX TrimAway® system regenerative blower



Converter Accessory Corporation

201 Alpha Road, PO Box 188, Wind Gap, PA 18091-0188

www.converteraccessory.com
sales@converteraccessory.com

Phone: 800-433-2413
610-863-6008

Fax: 800-709-1007
610-863-7818



Converter Accessory Corporation
www.converteraccessory.com



Pneumatic Conveying Systems
www.foxtrimaway.com



Three Venturi Sizes Available

FX1 Venturi

FX2 Venturi

FX3 Venturi



For more information on our venturi's, visit:
www.converteraccessory.com/components

Which Venturi is right for me?

FOX TrimAway® venturi's are designed for efficient removal of flexible to semi-rigid materials, such as web edge trim, pieces and matrix and are designed to operate in conjunction with regenerative type blowers. Air flow thru each venturi can vary greatly depending on the blower size with which it is teamed; CAC engineers will assist each customer with the proper venturi / blower combination for your application. Venturi's are normally tuned for maximum suction and air flow prior to shipment to the customer; however, all venturi models are adjustable in the field. All venturi models can be PTFE lined where exposed pressure sensitive adhesives must be handled.

FX1 Venturi - This venturi is generally used for narrow trim (up to 1") and relatively short conveying distances (up to 50'). FX1 venturi's are typically used for flexible trim at relative slow to intermediate speeds. The FX1 is approximately 11.5" long, 1.5" diameter at the suction and 2" diameter at the discharge (pressure). Typical regenerative blower sizing is between .5 HP to 2 HP.

FX2 Venturi - This venturi is our mid-size venturi and is our most popular model. It can handle trim up to 2" wide (sometimes wider depending on the trims flexibility). Conveying distances can range from 10' to approximately 100'. FX2 venturi's can handle trim that is flexible to semi-rigid. Trim speed can vary from just a few feet per minute up to over 4,000 feet per minute. The FX2 is approximately 24" long, 2.5" diameter at the suction and 4" diameter at the discharge (pressure). Typical regenerative blower sizing is between 2 HP to 10 HP.

FX3 Venturi - This is our largest model of venturi. It can handle trim over 3" wide. Conveying distances can range from 10 feet to well over 100 feet. FX3 venturi's can handle trim that is flexible to semi-rigid. Trim speed can vary from just a few feet per minute to over 6,000 feet per minute. The FX3 is approximately 29" long, 4" diameter at the suction and 5" diameter at the discharge. The inside diameter tapers down to 3". Typical regenerative blower sizing is between 5 HP up to 20 HP.



Venturi Accessories

For more information on these components, visit:
www.converteraccessory.com/components

Pneumatic Conveying Systems
www.foxtrimaway.com

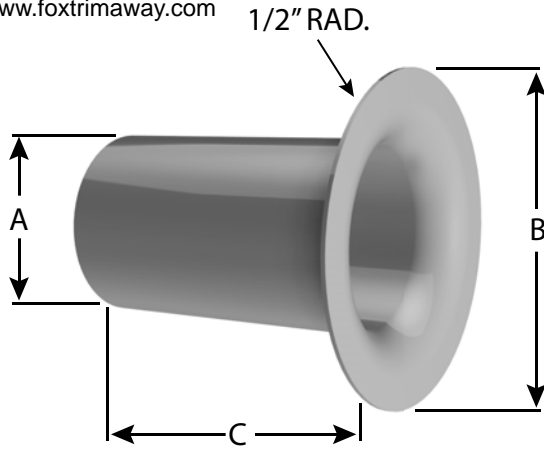

Pick Up Nozzles

FOX TrimAway pick up nozzles are trumpet shaped to eliminate the possibility of trim snags. Standard construction is epoxy painted (gray) steel for long life. Pick up nozzles come in three sizes to fit perfectly with our unique venturi systems but they also work well with almost any pneumatic trim removal system.

Pick Up Nozzle	A	B	C
1.50"	1.50	2.75	4.50
2.50"	2.50	4.25	4.50
4.00"	4.00	6.00	7.00

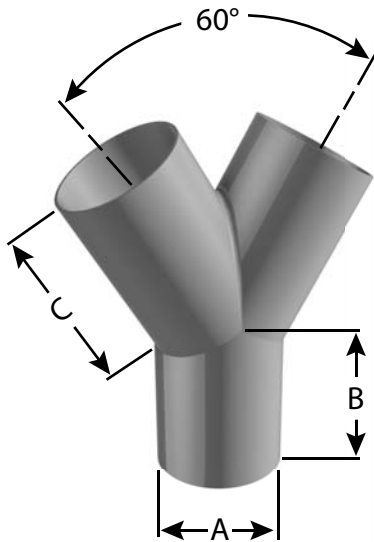

Y Connector

Y Connectors from FOX TrimAway are typically used for connecting two pick points to feed them into one venturi. Standard construction is epoxy painted (gray) steel for long life. Y connectors come in four sizes that are engineered for use with FOX TrimAway pneumatic trim removal systems. However, they work equally well with almost any trim removal system.

Y Connector	A	B	C
1.50"	1.50	2.50	2.50
2.00"	2.00	3.25	2.75
2.50"	2.50	3.00	3.50
4.00"	4.00	5.00	7.00

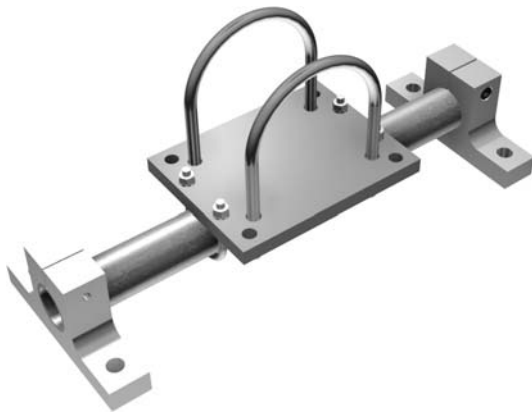

Venturi Mounting Bracket

The optional venturi mounting bracket will allow for easy mounting of any of the FOX TrimAway venturis. These brackets are available in three unique sizes, each designed to fit the FX1, FX2 and FX3 venturis.



Converter Accessory Corporation

201 Alpha Road, PO Box 188, Wind Gap, PA 18091-0188

www.converteraccessory.com
sales@converteraccessory.com

Phone: 800-433-2413
 610-863-6008

Fax: 800-709-1007
 610-863-7818



Converter Accessory Corporation
www.converteraccessory.com



Pneumatic Conveying Systems
www.foxtrimaway.com



Complete list of available blowers below

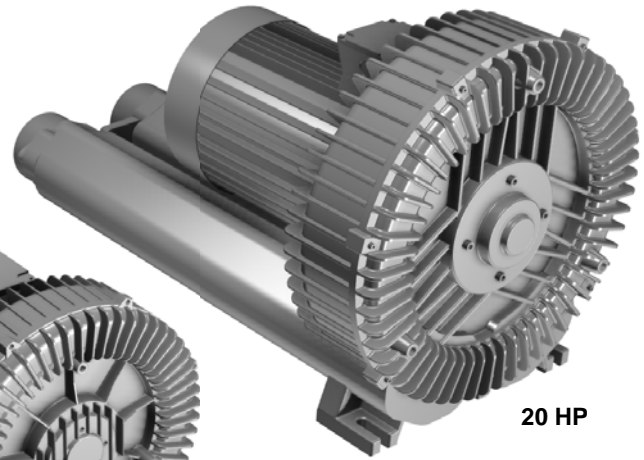
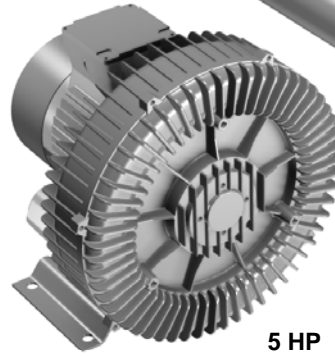

For more information on our blowers, visit: www.converteraccessory.com/blower

Particularly well suited for use with CAC's FOX TrimAway® pneumatic trim removal systems, regenerative blowers deliver **powerful, energy efficient and quiet performance.**

- Blowers are available for 50 and 60 Hz operation
- Noise levels are well below competitors
- Light weight, compact design - easy installation
- Virtually maintenance free operation - double shielded, sealed stainless steel bearings
- Efficient electricity consumption to save you money
- Full complement of accessories including filters, silencers, starters and VFD's available

Approximate Dimensions (in inches)						Noise Levels (approx dba at vacuum)	Use with Venturi	Approx Conveying Distance
Model	HP	A	B	C	Weight (lbs.)			
300AB	.50	9.05	9.64	9.78	25	61	FX1	10 - 15'
400AB	.67	9.05	9.64	9.78	24	61	FX1	10 - 15'
350AB	1.00	11.22	11.89	10.23	35	64	FX1	30'
450AB	1.25	11.22	11.89	10.23	31	64	FX1	30'
500AB	2.00	13.11	13.30	12.40	57	70	FX2	50'
501AB	2.00	13.11	13.30	12.40	49	70	FX2	50'
600AB	3.50	11.65	13.30	12.51	51	70	FX1, FX2	50 - 75'
700AB	5.00	15.00	15.03	14.44	75	72	FX2, FX3	100' +
800AB	10.00	18.11	19.48	17.12	185	80	FX2, FX3	100' +
1015AB	20.00	21.92	22.67	39.28	247	81	FX3	150' +

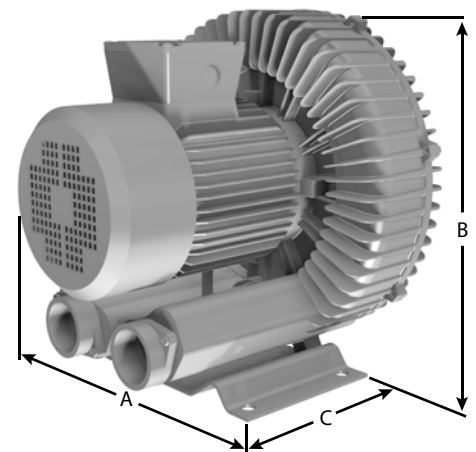

Electrical Data										
Electrical Data	Single Phase			Three Phase						
Model	300AB	350AB	500AB	400AB	450AB	501AB	600AB	700AB	800AB	1015AB
Voltage	110-120/ 220-240	110-120/ 220-240	110-120/ 220-240	220-275/ 380-480	220-275/ 380-480	220-275/ 380-480	220-275/ 380-480	220-275/ 380-480	220-275/ 380-480	220-275/ 380-480
Current / Amp	7.80Δ/ 3.90Y	13.00Δ/ 6.50Y	23.00Δ/ 11.50Y	2.30Δ/ 1.30Y	3.90Δ/ 2.30Y	6.00Δ/ 3.50Y	7.00Δ/ 4.00Y	13.50Δ/ 7.80Y	26.00Δ/ 13.00Y	51.50Δ/ 29.80Y
Output Horsepower	.50	1.00	2.00	.67	1.25	2.00	3.50	5.00	10.00	20.00



Pneumatic Conveying Systems
www.foxtrimaway.com

Blower Accessories

For more information, including dimensions on these components, visit:

www.converteraccessory.com/blower



Filter Canister and Element

Filter canister with filter element is always recommended for suction of the blower. The filter assembly will keep clean, dry air entering the blower. It will remove particulate matter and contaminants which have the potential to damage the blower.



Silencer

Add one (suction side) or a second silencer (pressure side) to your blower to reduce noise generated by the blower. Adding up to two silencers can decrease decibel level by up to 10DB. The level of noise reduction will vary depending on which blower and silencer(s) are combined.



Motor Starter

NEMA 4X, prewired START/STOP 3-wire control with through-the-cover overload RESET. Single phase or 3 phase models available. It includes an adjustable trip current and selectable manual or automatic reset. This is basically an on/off switch for your blower.



Variable Frequency Drive (VFD)

A VFD allows you to control the speed of the AC motor on the blower, which is powering your trim removal system. By controlling the speed of the motor, you then control the amount of air through the trim removal system. This may help you fine tune the system for optimum performance for your lightest to heaviest application, thereby decreasing noise, saving power and eliminating trim-breaks.



Converter Accessory Corporation

201 Alpha Road, PO Box 188, Wind Gap, PA 18091-0188

www.converteraccessory.com
sales@converteraccessory.com

Phone: 800-433-2413
610-863-6008

Fax: 800-709-1007
610-863-7818



Converter Accessory Corporation
www.converteraccessory.com



Pneumatic Conveying Systems
www.foxtrimaway.com



For more information
on this system, visit:

www.converteraccessory.com/matrix

Matrix Removal System

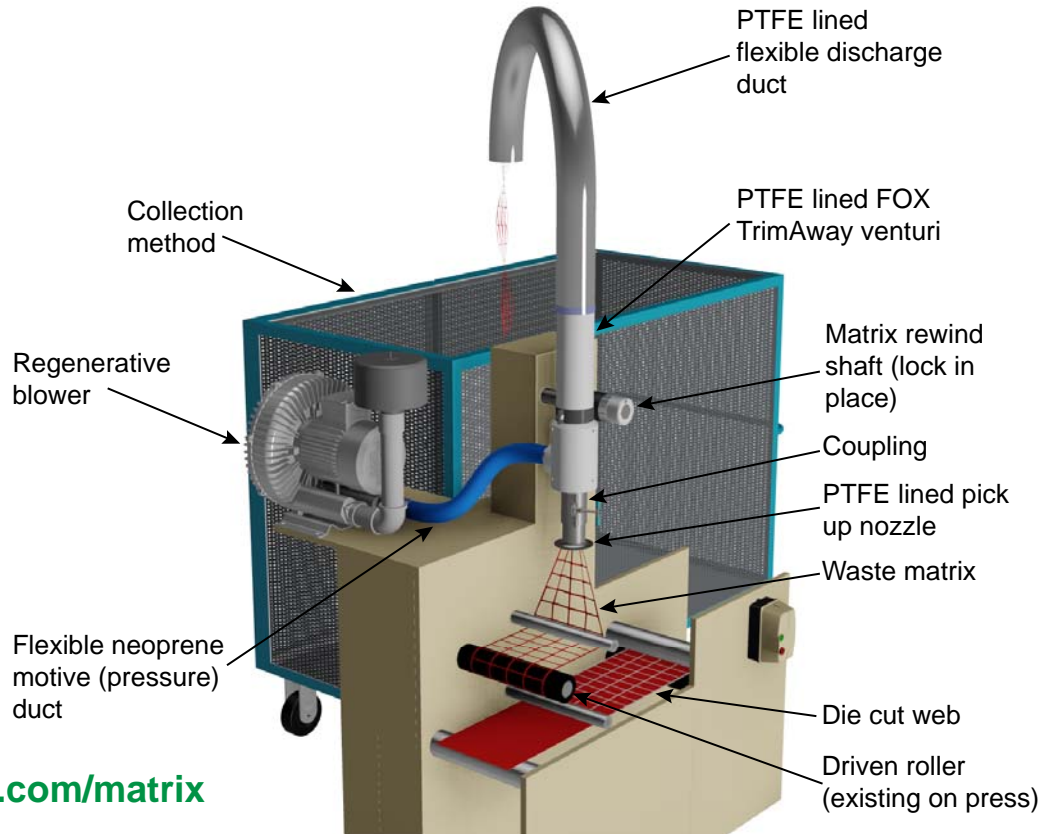

Unique Approach to Matrix Removal

Traditionally, label and die cut matrix is wound onto a scrap rewind shaft. This method of waste removal and collection has several drawbacks that results in costly machine downtime. Rolls must be changed frequently, resulting in press stoppage. Tension control becomes very difficult at larger roll diameters, resulting in matrix breaks. Label manufacturers may run more expensive, wider than necessary webs to combat matrix breaks. Often times recycling efforts are complicated by the cardboard core necessary to rewind the matrix roll.

FOX TrimAway® eliminates the need for rewinding matrix. Advantages to using FOX TrimAway matrix removal include:

- **Zero** machine stops to remove full matrix rolls
- Easy recycling without a cardboard core
- FOX TrimAway matrix removal systems utilize PTFE lined components. Matrix **won't adhere** to the internal surfaces and messy oil injection systems are not necessary.
- PTFE lined and plasma coated choppers are available to chop matrix without the use of oil injection.
- System setup is **FAST** and **EASY**. The unique FOX TrimAway venturi is supplied with a special mounting bracket to mount directly to the existing matrix rewind shaft. The matrix threading stays consistent with rewinding threading pattern. The blower may be mounted to the floor or machine frame. Duct work is flexible, semi-rigid to ease the routing to the collection method.
- **Elimination** of web breaks with an adjustable and constant vacuum level. This may allow you to run narrower webs, saving you money.
- FOX TrimAway matrix removal systems are **available** with 5HP up to 20 HP blowers and a choice of two different venturi sizes. Up to 22" wide matrix, up to 700 FPM may be handled.
- FOX Runner matrix removal systems are available where a portable system is desired.



Pneumatic Conveying Systems
www.foxtrimaway.com

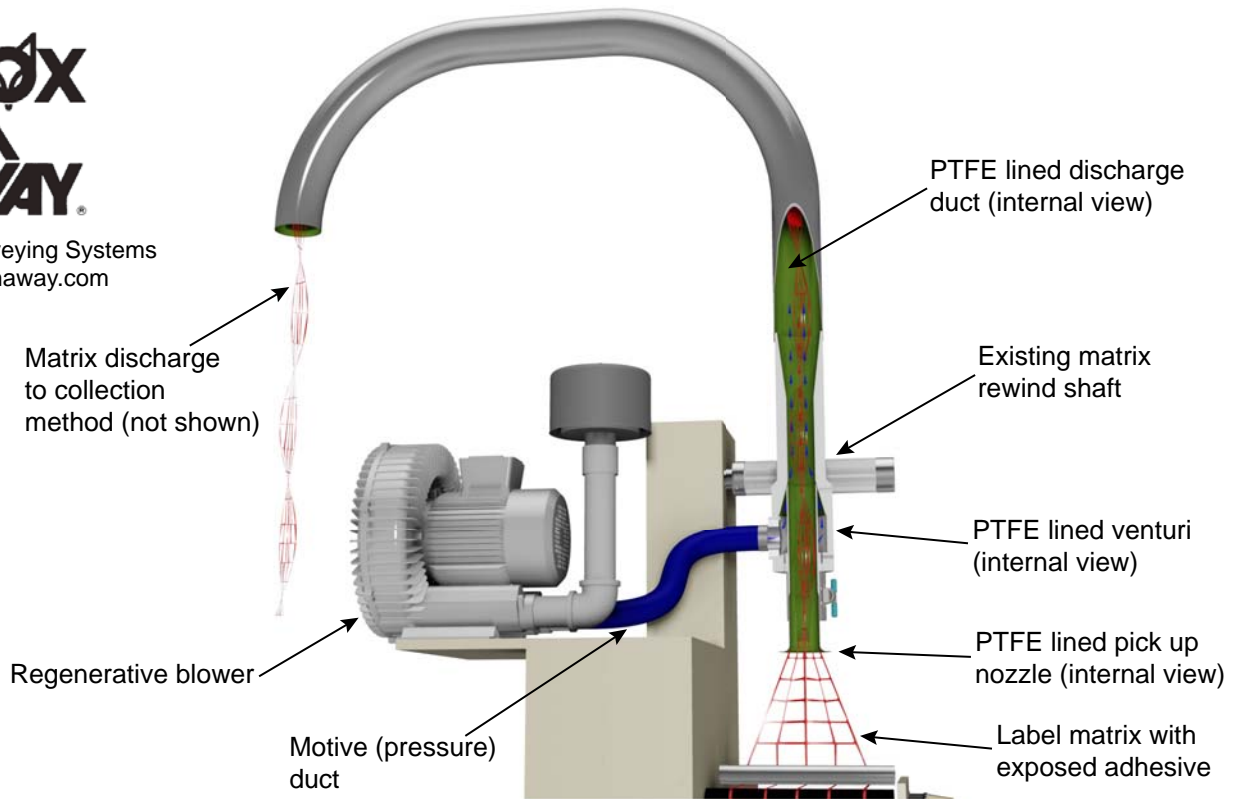

Unique Approach to Matrix Removal

FOX TrimAway® pneumatic matrix removal systems utilize powerful and efficient regenerative blowers to generate “motive” air stream. The FOX TrimAway venturi is designed to produce adjustable suction and pressure to convey your waste matrix.

The matrix remains in its' typical threading pattern through the machine but instead of rewinding, it is fed into the suction side of the venturi. There is no need to chop the matrix. FOX TrimAway pneumatic matrix removal systems use PTFE lined components to effectively remove matrix with aggressive adhesives. FOX TrimAway does not use oil or powder, keeping your facility clean of contaminants.

Typical applications include:

- Paper, label stock, tag stock, foils, films
- Adhesive and non-adhesive matrix
- Narrow to widths up to 22"
- Speeds up to 700 feet per minute
- Label presses and die cutters

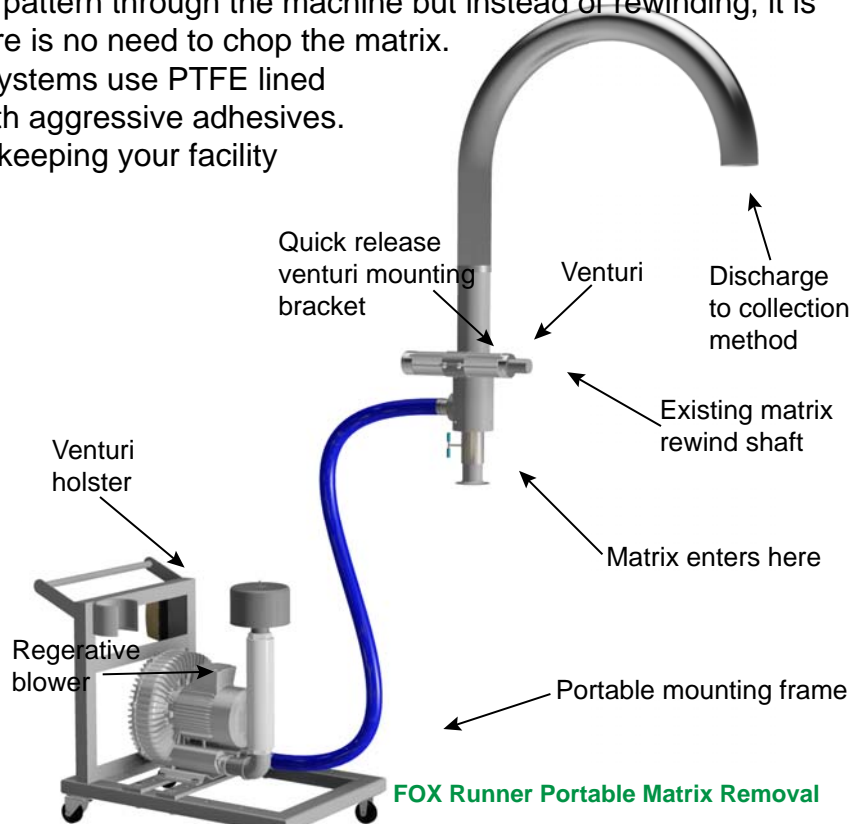

Converter Accessory Corporation

201 Alpha Road, PO Box 188, Wind Gap, PA 18091-0188

www.converteraccessory.com
sales@converteraccessory.com

Phone: 800-433-2413
610-863-6008

Fax: 800-709-1007
610-863-7818



Converter Accessory Corporation
www.converteraccessory.com



Pneumatic Conveying Systems
www.foxtrimaway.com



FOX Runner™ Portable Pneumatic Waste Removal Systems



Two Pick-up FOX Runner™ Portable System



One Pick-up FOX Runner™ Portable System

For more information on this system, visit:

www.converteraccessory.com/runner

FOX Runner™ utilizes CAC's standard FOX TrimAway® pneumatic waste removal systems. These portable systems are shipped completely assembled and ready to use. As with all FOX TrimAway systems, FOX Runner has a unique venturi at its' heart. Teamed with a powerful, efficient and quiet regenerative blower, FOX Runner is able to generate suction and pressure air streams to pick up and convey your edge trim, die cut pieces or matrix from your machine.

- **Turn key** for fast and easy installation and operation
- Portable for operation at different stations
- Frame is heavy duty construction on durable castors
- Venturi is aluminum construction - adjustable for individual requirements
- Regenerative blower is **energy efficient**, quiet and low maintance
- Ducting is semi rigid



Pneumatic Conveying Systems
www.foxtrimaway.com

FOX Runner™ systems are available for matrix removal where portability is desired. Similar to FOX TrimAway's standard pneumatic matrix removal systems, FOX Runner matrix removal systems are PTFE lined to stop exposed adhesives adherence to system components.

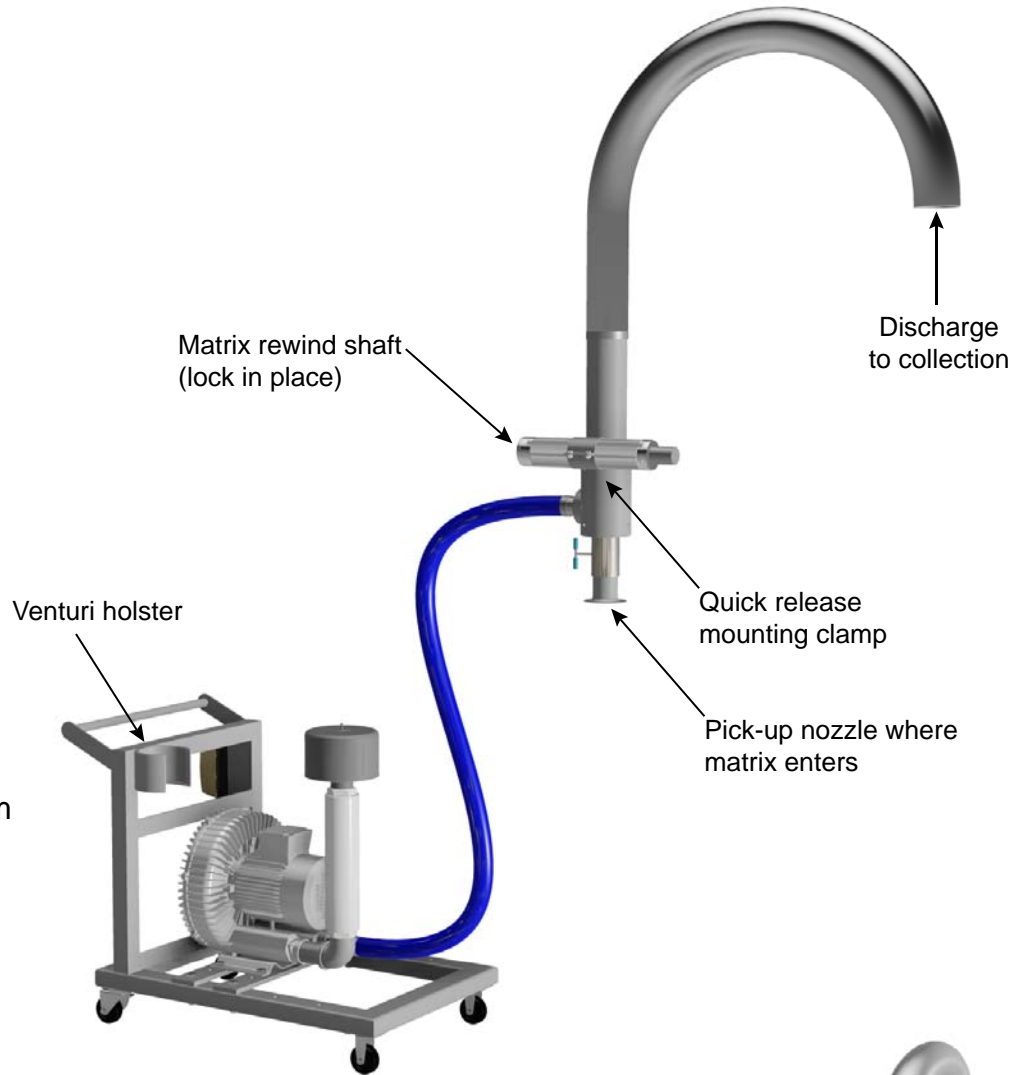

Matrix Removal FOX Runner™ Portable System

FOX Runner™ systems are available with CAC's built-in Trim-AX chopper where it is desired to chop edge trim or waste matrix. Chopped edge trim is much easier to convey long distances. It is easier to dispose of and waste containers last much longer between emptying.

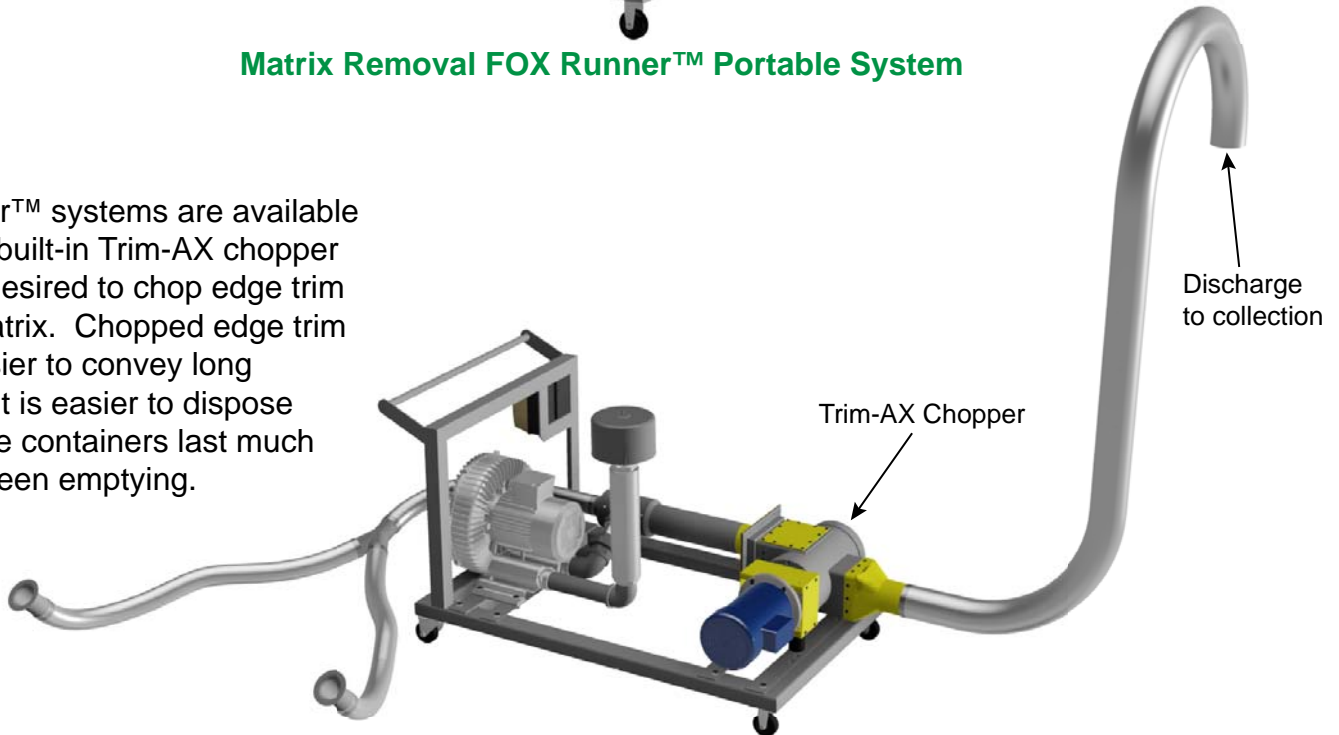

FOX Runner™ Portable System with Chopper



Converter Accessory Corporation

201 Alpha Road, PO Box 188, Wind Gap, PA 18091-0188

www.converteraccessory.com
sales@converteraccessory.com

Phone: 800-433-2413
610-863-6008

Fax: 800-709-1007
610-863-7818



Converter Accessory Corporation
www.converteraccessory.com



Pneumatic Conveying Systems
www.foxtrimaway.com



Trim-AX™ Heavy Duty Chopper

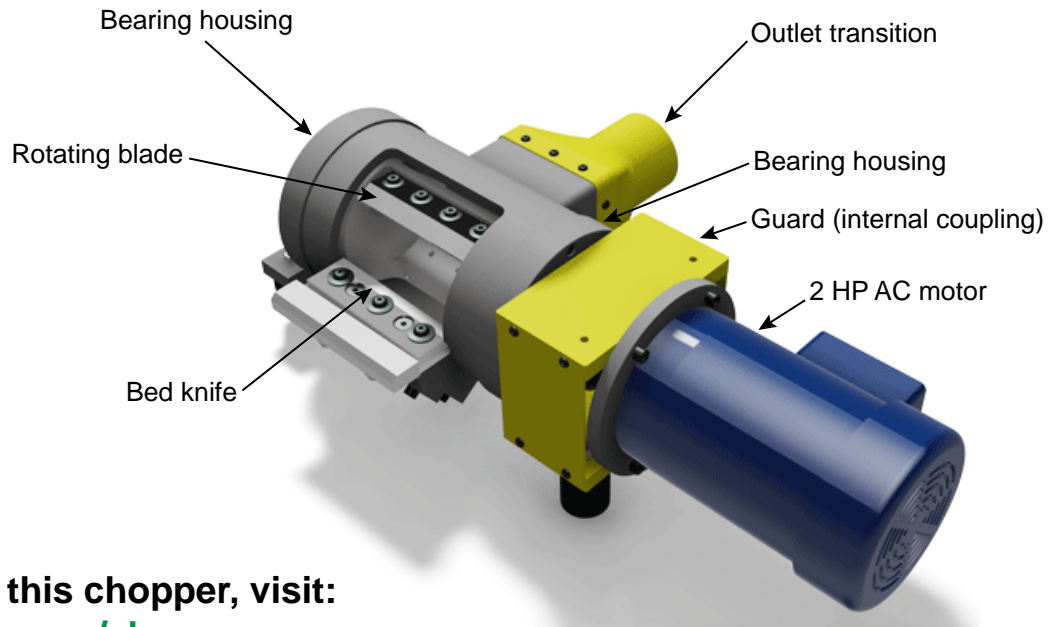

For more information on this chopper, visit:
www.converteraccessory.com/chopper

CAC's Trim-AX™ heavy duty chopper utilizes a superior design to chop extremely light to very thick and heavy materials. Trim-AX is precision engineered with dual bearing support between rotor and each bearing housing. It's all steel construction is manufactured using precision CNC machining centers to ensure very tight tolerances between rotating blade and bed knife. Vibration, noise and maintenance is all kept to a minimum due to superior engineering, design and manufacturing practices.

Specifically designed to fit CAC's FOX TrimAway® pneumatic waste removal systems, Trim-AX choppers offer seamless integration with CAC's line of pneumatic waste removal systems. Trim-AX may also be integrated into existing systems.

Design Features:

- Two bladed design supplies approximately 3,450 chops per minute with a 1,725 RPM motor
- **Exceptionally stable** with dual bearing support at each bearing housing and heavy duty construction
- Works well with FOX TrimAway®, FOX Runner™ and other pneumatic conveying systems
- Chopped edge trim is much **easier to convey** than continuous length of trim, allowing for a very long (200+ feet) pneumatic conveying lengths
- Chopped edge trim takes up less space in collection methods. Waste handling and emptying of collection methods will decrease with chopped edge trim.
- 2HP standard
- Built to last

Applications:

- Thin to thick films
- Light to heavy paper
- Foils
- Nonwovens
- Carpet
- Heavy plastics

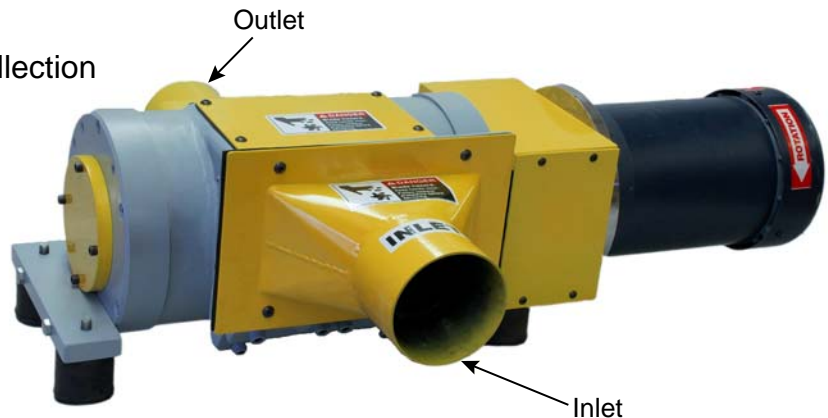



Pneumatic Conveying Systems
www.foxtrimaway.com

Collection Methods

Collection Bags:

- Nylon construction
- 4" Diameter top opening with string closure
- Velcro opening for easy cleanout
- Two sizes available
- Standard = 30" diameter (at base) x 72" long
- Large = 60" diameter (at base) x 144" long

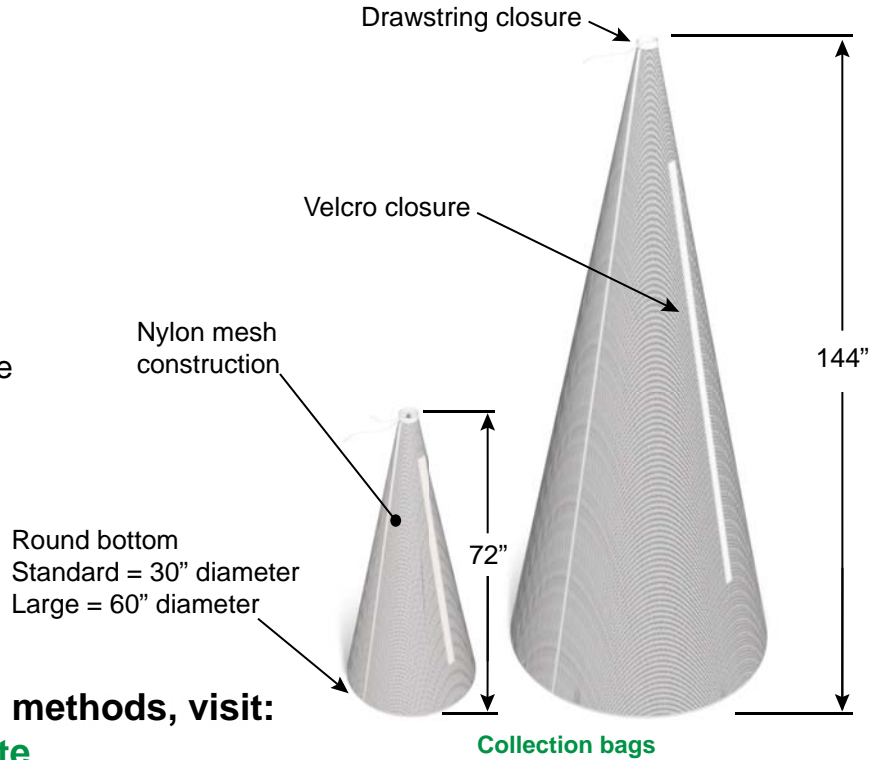

For more information on collection methods, visit:

www.converteraccessory.com/waste

CAC's FOX TrimAway® pneumatic conveying systems division offers several waste collection methods. These collection methods include systems to collect edge trim as it exits the FOX TrimAway system while allowing the conveying air to exhaust to atmosphere.

Collection Bin:

- Constructed of expanded metal
- Hinged cleanout door for easy waste removal
- Mounted on swivel casters for easy positioning
- Measures 36" W x 72" L x 48" H
- 72 Cubic feet of capacity

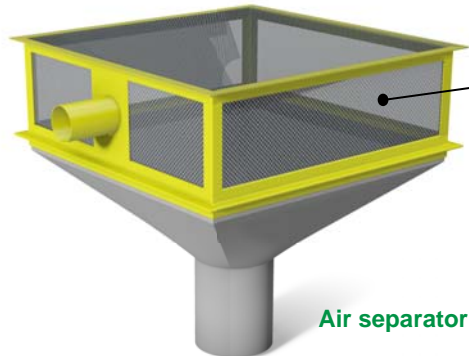

Air separator



Collection bin

FOX TrimAway's air separator allows conveying air to exhaust to atmosphere while edge trim or other waste "gravity feeds" through the bottom of the unit. It is constructed of expanded metal and is approximately 39" W x 39" x L x 39" H with a 10" diameter opening at the bottom.



Converter Accessory Corporation

201 Alpha Road, PO Box 188, Wind Gap, PA 18091-0188

www.converteraccessory.com
sales@converteraccessory.com

Phone: 800-433-2413
610-863-6008

Fax: 800-709-1007
610-863-7818





Converter Accessory Corporation
www.converteraccessory.com



Pneumatic Conveying Systems
www.foxtrimaway.com

Duct Options

Flexible Steel Duct for Intake (suction) and Discharge (pressure)

FOX TrimAway's® flexible steel duct is an excellent choice for continuous lengths up to 50 feet and for bends joining rigid, straight duct lengths. This semi-rigid duct allows you to easily route your trim around machine framework and connect pick-up nozzles, wye connectors, venturi and collection method. Flexible steel duct is sold in continuous lengths of multiples of 5 feet. Bulk lengths of 25 feet and 50 feet are available. This duct may be PTFE lined in lengths up to 10 feet maximum; several lengths may be coupled together where longer lengths are required.

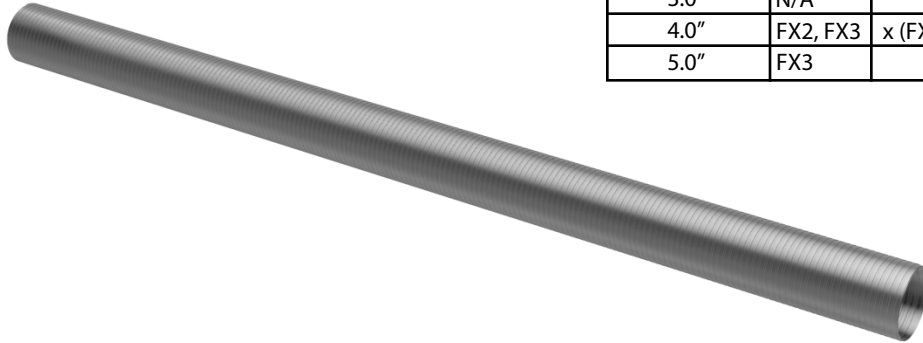

Nominal Inside Diameter	Use with Venturi	Intake	Discharge	Minimum Bending Radius
1.5"	FX1	x		7"
2.0"	FX1		x	24"
2.5"	FX2	x		27"
3.0"	N/A			32"
4.0"	FX2, FX3	x (FX3)	x (FX2)	42"
5.0"	FX3		x	48"

Flexible Neoprene Composite Duct for Motive (connects blower to venturi)

FOX TrimAway's® flexible neoprene composite duct is used to connect a blower to the FOX TrimAway venturi. This duct is very flexible, allowing easy routing thru machine frames. Neoprene composite construction is heat resistant and designed to deliver the maximum amount of pneumatic pressure from the blower to the venturi. Flexible neoprene composite duct is sold in continuous lengths of multiples of 5 feet with bulk lengths of 25 feet available.

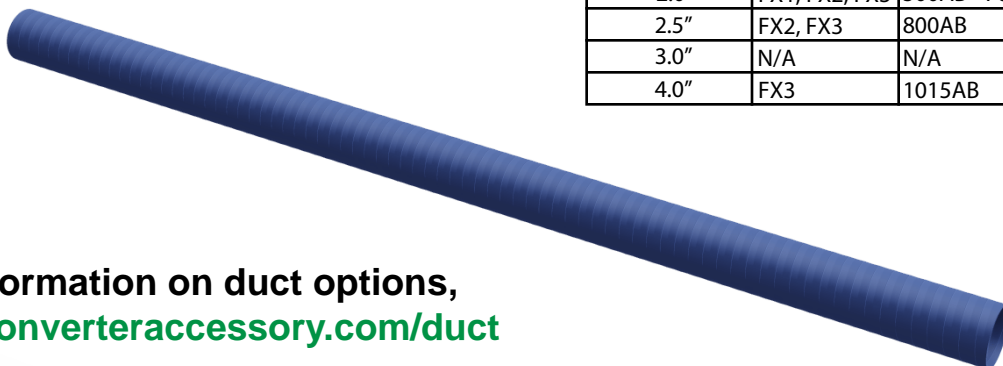

Nominal Inside Diameter	Use with Venturi	Use with Blower Model	Minimum Bending Radius
1.5"	FX1	300AB - 450AB	15"
2.0"	FX1, FX2, FX3	500AB - 700AB	15"
2.5"	FX2, FX3	800AB	20"
3.0"	N/A	N/A	20"
4.0"	FX3	1015AB	48"

For more information on duct options,
visit: www.converteraccessory.com/duct





Pneumatic Conveying Systems
www.foxtrimaway.com

Duct Options

Rigid Steel Duct

FOX TrimAway's® rigid steel duct is an excellent choice where long (over 20 feet), continuous duct runs are required. Standard construction is heavy duty 16 gauge galvanized steel. Standard straight lengths come in 20 foot lengths. Elbows and straight lengths (10 feet maximum length) may be PTFE lined for applications involving adhesive coated waste. Elbows and multiple straight lengths may be coupled together to suit your plant requirements.



90°



45°

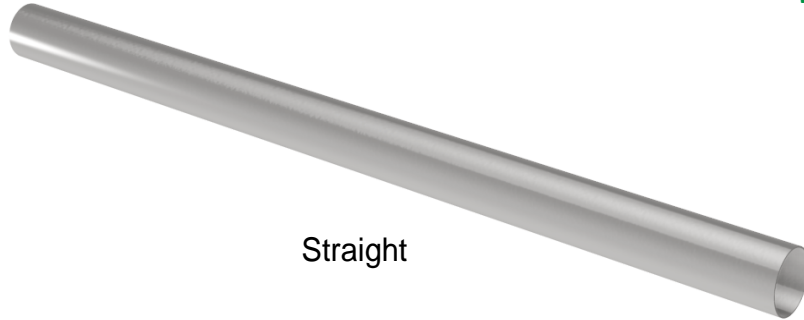

Straight

Nominal Inside Diameter	Use with Venturi	Motive (Blower Model)	Intake	Discharge	Radius
2.5"	FX2	800AB	x		36"
3.0"	FX3	N/A			48"
4.0"	FX2, FX3	1015AB	x (FX3)	x (FX2)	48"
5.0"	FX3	N/A		x	48"

For more information on duct options, visit: www.converteraccessory.com/duct



High Torque Duct Clamp

High torque duct clamps are used for attaching FOX TrimAway® venturis, pick up nozzles and wye's to flexible duct. These clamps are available in all duct sizes available with FOX TrimAway systems.



Coupling Assembly

Coupling assemblies are used to join multiple lengths of flexible duct. They are available in all duct sizes available with FOX TrimAway systems.



Rigid Duct Coupling

Rigid duct couplings are used for attaching elbows and multiple straight duct lengths.



Converter Accessory Corporation

201 Alpha Road, PO Box 188, Wind Gap, PA 18091-0188

www.converteraccessory.com
sales@converteraccessory.com

Phone: 800-433-2413
610-863-6008

Fax: 800-709-1007
610-863-7818